

**DT TRAILER 80**



**WARNING!**  
MAX. CAGE LOAD 1b 507 (kg 230)  
INCLUDING 2 PERSONS AND 104 lb (79 kg) EQUIPMENT

**DT TRAILER 25**

## STANDARD EQUIPMENT

|  |  |
|--|--|
| Double telescopic extension booms  | 110/220V Power supply to the basket                      |
| Rear oriented boom position  | Electronic controlled level alarm/sensor                 |
| High torque drive system   | Hitch pull bar   |
| Auto levelling basket  | Hour meter   |
| Hydraulic outriggers   | 2 people basket (140x70x110 cm / 55x27x43 in)            |
| Outrigger interlocks   | All function radio control                               |
| Easy to access batteries   | Telescopic boom painting: blue RAL 9010 - white RAL 9010 |
| Dual power sources - diesel engine and 110/220VAC electric / lithium available | Cylinders, turret and pistons painting: white RAL 9010   |
| Fully electronic proportional hydraulic controls driven by can-bus system      | Automatic stabilization (optional)                       |
|  | Remote management and diagnostic software (optional)     |

## OPTIONS & ACCESSORIES

|   |  |
|---|--|
| Anti debris brushes on booms                          | Dead man pedal in the basket   |
| Small personnel basket (70x70x110 cm or 27x27x43 in)  | Air/water connection line between basket and turret, max pressure 100bar |
| Large personnel basket (180x70x110 cm or 70x27x43 in) | Ultrasonic anti collision alarm for basket protection                    |
| Fiberglass basket (optional 1 kV insulation)          | Remote management and diagnostic software                                |
| Hoist hook (max 260 kg or 573 lbs)                    | N.4 ground use plates for stabilization                                  |
| Radio controlled winch (max 230 kg or 507 lbs)        | Custom paint options available (upper and lower sections)                |
| Material handling cage (max 200 kg or 441 lbs)        | Customized stickers with customer logo                                   |
| Security belts  | Up to 5 years extended warranty  |
| Illuminated outrigger indicators                      |  |
| One click auto-closing switch                         |  |

## STANDARD TRAILER FEATURES

|   |                                 |
|---|---------------------------------|
| Hydraulic drive controlled by remote control                  | Hydraulic brakes                |
| Stabilization controlled by remote control                    | Foldable cyclist protection bar |
| Low center of gravity that allows for highly safe drivability | Side marker lights              |
| Single jockey wheels  | Removable light bar             |

## UNIQUE

|  |
|--|
| Unbeaten working envelope                          |
| Unmatchable ultra wide negative working envelope   |
| Highest up & over in the Industry                  |
| Very low centre of gravity, impressive drivability |

## STANDARD COMPLIANCE











|   |
|---|
| ANSI 92.20  |
| UNI EN 280  |
| CSA B354.6  |
| CE  |
| Crane certification (EN 12999 standard certified) |



## PERFORMANCE

|   | <i>metric</i>   | <i>US</i>    |
|---|---|--------------|
| Working height  | 25 m  | 82 ft        |
| Platform height   | 23 m  | 75 ft 5 in   |
| Horizontal outreach                                       | 12 m  | 39 ft 4 in   |
| Up and over clearance                                     | 14 m  | 45 ft 11 in  |
| Negative work (below ground level)                        | -5 m  | -16 ft 5 in  |
| Lift capacity - standard (ANSI - CSA - CE - AUS)          | 230 kg  | 507 lbs      |
| Lift capacity - rotating platform (ANSI - CSA - CE - AUS) | 230 kg  | 507 lbs      |
| Self leveling platform                                    | 5°standard  | 5°standard   |
| Platform rotation   | 180°  | 180°         |
| AC power to platform                                      | standard  | standard     |
| Turntable rotation  | 720°  | 720°         |
| Outrigger leveling capability                             | ≈ 5°  | ≈ 5°         |
| Gradeability  | 10°/13°   | 49%          |
| To be jacked up on ground slope max                       | 12°   | 12°          |
| Slope angle   | 11°   | 11°          |
| Drive speed   | 1,12 km/h   | 0,70 mph     |
| Towing speed rate   | 97 km/h   | 60 mph       |
| Tongue weight   | 140 kg  | 309 lbs      |
| Surge parking & brakes                                    | standard  | standard     |
| Controls  | electronic multifunction highly proportional controls |              |
| Tyre size   | 215/75 R17,5  | 215/75 R17,5 |
| Coupler   | 5 cm  | 2 in         |
| Live load/Max pressure in travelling position             | 4,3 kN/m2   | 90 lbs/ft2   |
| Live load/Max pressure in working position                | 2,5 kN/m2   | 52,2 lbs/ft2 |
| Point load per outrigger plate                            | 22 max Kn   | 4946 lbs     |
| Size of outrigger plate                                   | 200 mm  | 8 in         |

## MEASUREMENTS

|  | <i>metric</i> | <i>US</i>   |
|--|---------------|-------------|
|  Center of gravity                          | 1,1 m         | 3 ft 7 in   |
|  Platform length                            | 0,7 m         | 2 ft 4 in   |
|  Platform width                             | 1,4 m         | 4 ft 7 in   |
|  Height - stowed                            | 2,085 m       | 6 ft 10 in  |
|  Length - stowed                            | 5,925 m       | 19 ft 6 in  |
|  Width - stowed "(lightbar is demountable)" | 1,85 m        | 6 ft 1 in   |
|  Departure angle                            | 8°            | 15%         |
|  Length - outrigger footprint narrow        | 3,650 m       | 12 ft       |
|  Length - outrigger footprint wide          | 4,815 m       | 15 ft 10 in |
|  Width - outrigger footprint narrow         | 2,470 m       | 8 ft 1 in   |
|  Width - outrigger footprint wide           | 3,600 m       | 11 ft 10 in |

## POWER

|   | <i>metric</i>                | <i>US</i>                    |
|---|------------------------------|------------------------------|
| Multifunction proportional hydraulic flow-sharing distributor |                              |                              |
| Power source drive - standard                                 | diesel and electric          | diesel and electric          |
| Power source - option   | lithium                      | lithium                      |
| Fuel tank capacity  | 15 lt                        | 3,9 gals                     |
| Hydraulic tank capacity                                       | 120 lt                       | 31,7 gals                    |
| Hydraulic system capacity                                     | 150 lt                       | 40 gals                      |
| Sound pressure level (diesel)                                 | < 96 dBA                     | < 96 dBA                     |
| Sound pressure level (electric)                               | < 56 dBA * internally tested | < 56 dBA * internally tested |

## WEIGHT

|        | <i>metric</i> | <i>US</i> |
|--------|---------------|-----------|
| Weight | 3000 kg       | 6613 lbs  |

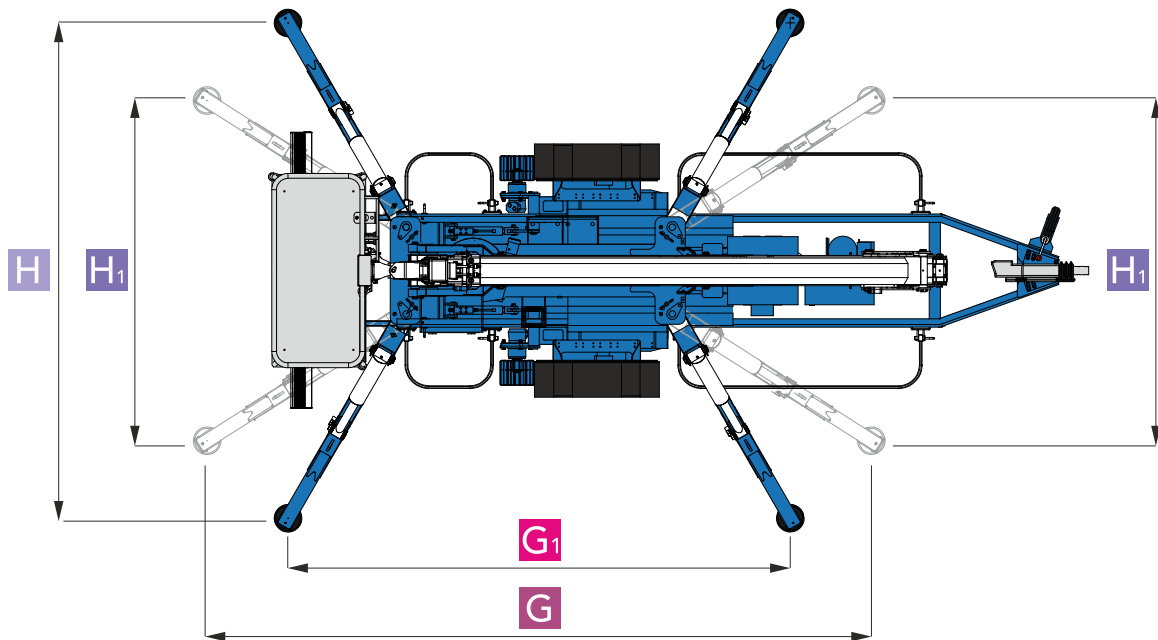
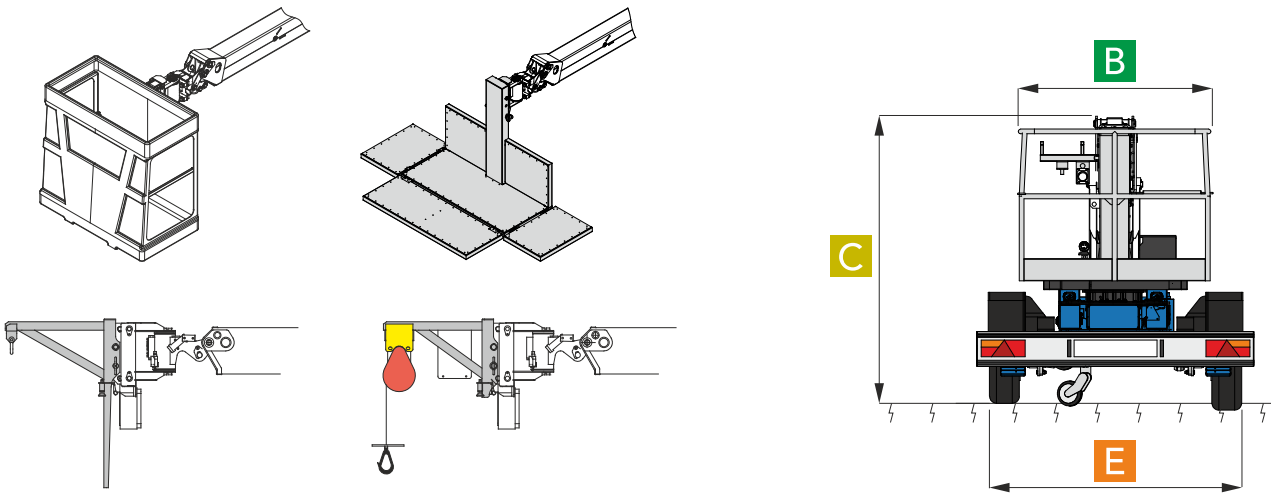
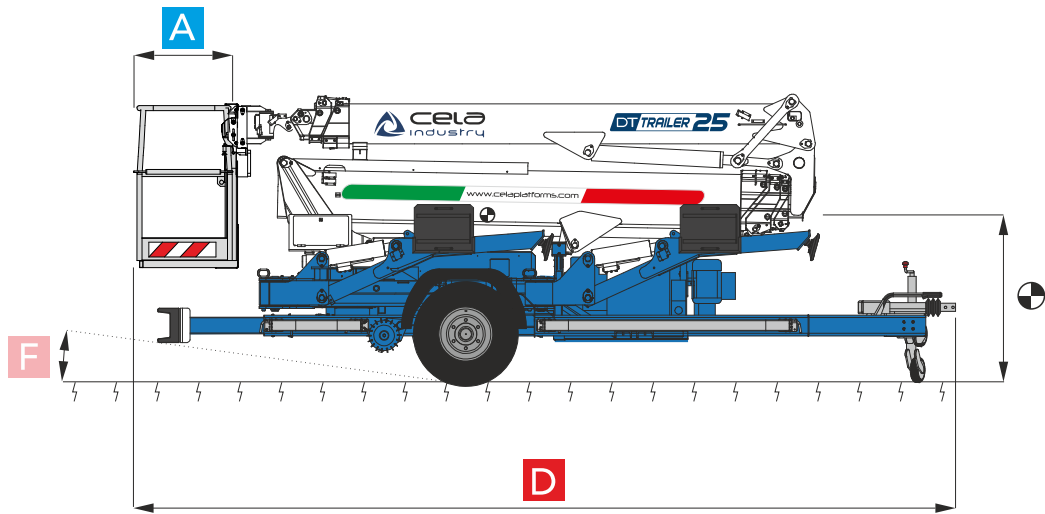

|                                    | <i>metric</i> | <i>US</i>   |
|------------------------------------|---------------|-------------|
| Working height                     | 25 m          | 82 ft       |
| Horizontal reach                   | 12 m          | 39 ft 4 in  |
| Up and over clearance              | 14 m          | 45 ft 11 in |
| Negative work (below ground level) | -5 m          | -16 ft 5 in |

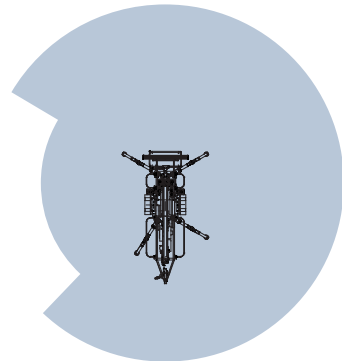
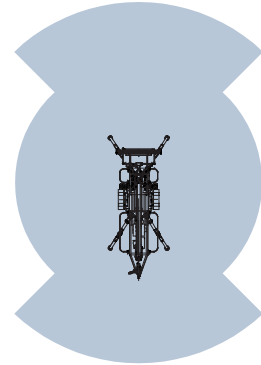
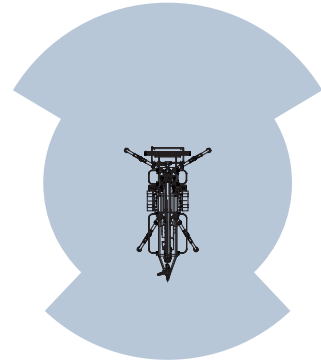
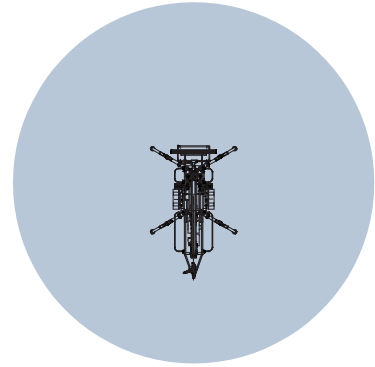
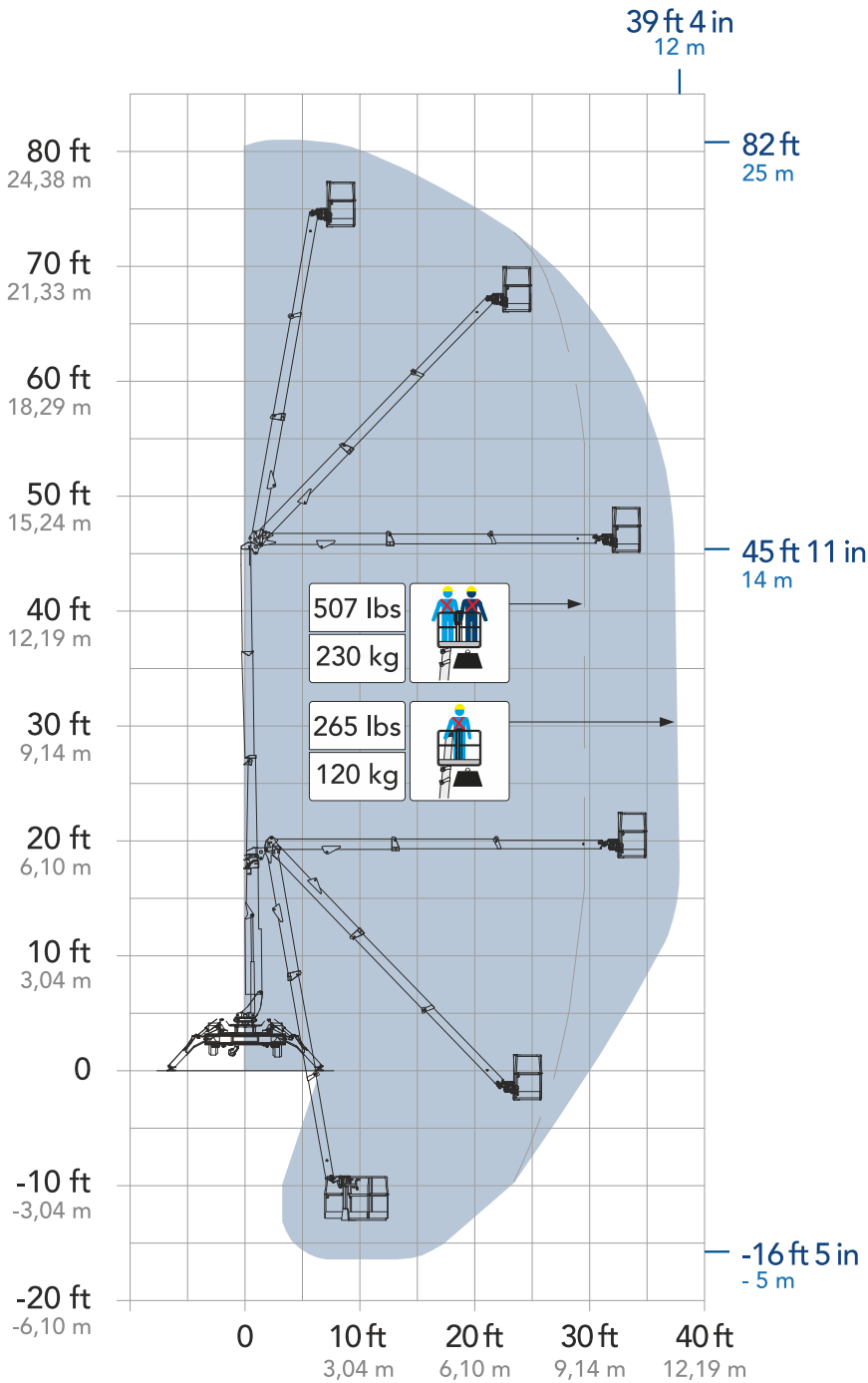



We fly all over

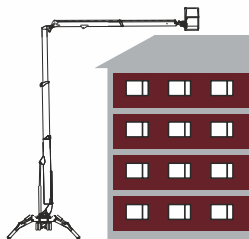

Manufacturer authorized exit at height

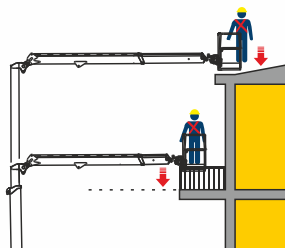

Multipurpose lifting options

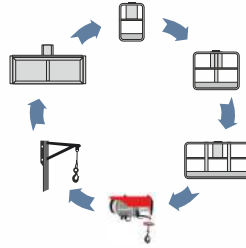

Like an elevator

